



5I-4 Driveway Design Criteria

A. General

For efficient and safe operations, access drives and minor public street intersections can be improved by the following:

- Smooth vertical geometrics
- Adequate driveway throat width and curb return radii
- Provide adequate sight distance
- Additional egress lane
- Quality driveway construction
- Define the ingress and egress sides of the access drive

B. Width measurement

1. The width of an entrance with a radius return or with a flared taper that connects to a curb and gutter roadway shall be measured at a point 10 feet back from the roadway curb. The curb opening may exceed the maximum allowable width of the entrance to accommodate the allowable radius or taper.
2. The width of an entrance that connects to a rural roadway (no curb and gutter) shall be measured across the top of the entrance at the culvert line or at the location where a culvert would normally be placed.

C. Dimensions

Figure 1: Entrance dimensions

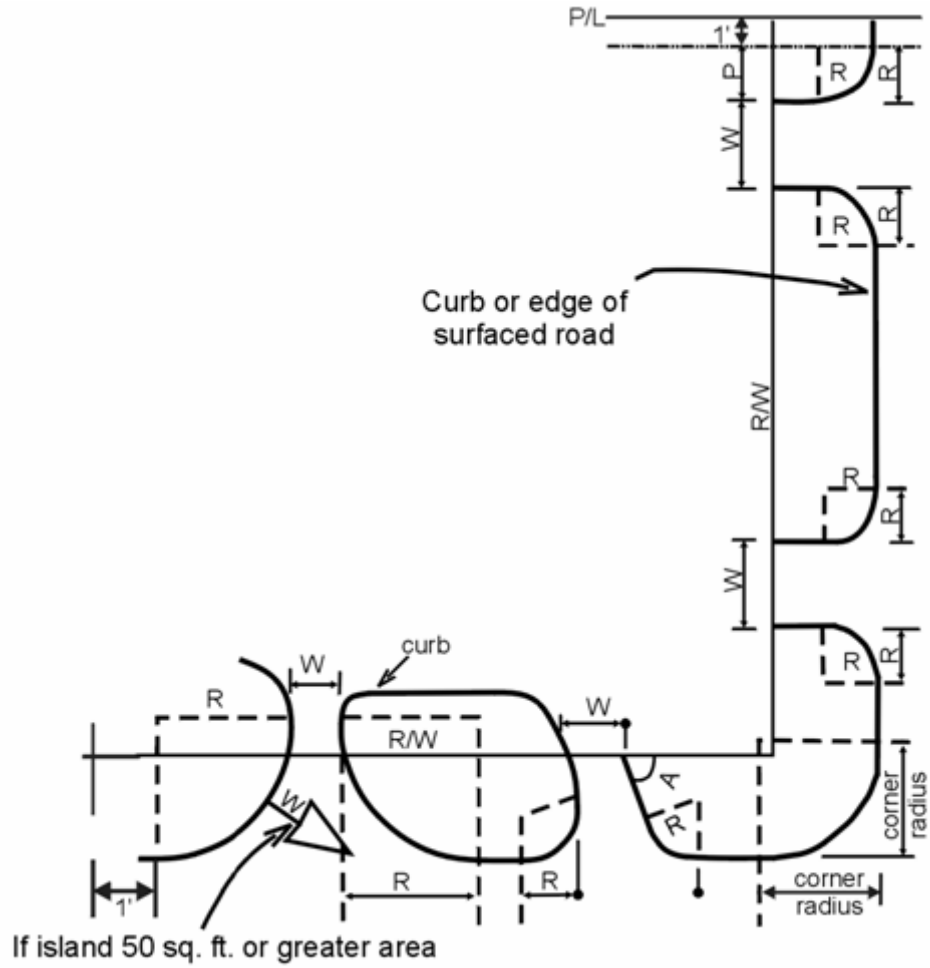

Table 1: Driveway dimensions
(all dimensions in feet)

Entrance Type ¹	Dimension Reference (See Section 5I-2, Figure 14)	Major/Principal Arterial Street				Minor/Arterial Street			
		Residential	Commercial	Industrial	Agricultural	Residential	Commercial	Industrial	Agricultural
		C	B	B	C	C	B	B	C
(a) Width	W								
Minimum		15	24	24	20	15	24	24	20
Maximum		30	45	45	30	30	45	45	30
(b) Right-turn Radius ²	R								
Minimum		10	10	25	25	10	10	25	25
Maximum		25	35	50	35	25	35	50	35
(c) Min. Acute Angle ⁴	A	60°	70°	70°	70°	60°	70°	70°	70°
Preferred Acute Angle		90°	90°	90°	90°	90°	90°	90°	90°
(d) Min. Pavement Thickness	T	6 in / 8 in	7 in / 9 in	*	6 in (If paved)	6 in	7 in	*	6 in (If paved)

1. Type “A” entrance requires special study.
 2. 3 ft Flares (F) may be used for residential & agricultural entrances.
 3. Minimum spacing from corner on resident property that access to a minor arterial street may be adjusted if lot frontage is limited. Larger lots with larger frontage may be required on corner lots.
 4. Any variation from 90° will be evaluated on a case by case basis. The minimum acute angle (measured from the edge of the pavement) is 60°.
- * Requires special design.

Entrance Type ¹	Dimension Reference (See Section 5I-2, Figure 14)	Collector (Major & Minor)				Local Street			
		Residential	Commercial	Industrial	Agricultural	Residential	Commercial	Industrial	Agricultural
		C	B	B	C	C	B	B	C
(a) Width	W								
Minimum		10	24	24	20	10	24	24	20
Maximum		24	40	45	30	24	32	40	30
(b) Right-turn Radius ²	R								
Minimum		10	10	25	25	10	10	10	20
Maximum		25	35	50	35	15	20	30	35
(c) Min. Acute Angle ⁴	A	60°	70°	70°	70°	60°	70°	70°	70°
Preferred Acute Angle		90°	90°	90°	90°	90°	90°	90°	90°
(d) Min. Pavement Thickness	T	6 in	7 in	*	6 in (If paved)	6 in	7 in	*	6 in (If paved)

1. Type “A” entrance requires special study.
 2. 3 ft flares (F) may be used for residential & agricultural entrances.
 3. Any variation from 90° will be evaluated on a case by case basis. The minimum acute angle (measured from the edge of the pavement) is 60°.
- * Requires special design

1. The minimum width (W) under local streets is intended to apply to one-way operation. In high pedestrian activity areas, such as in a central business district or in the same block with auditorium, school, or library, the basic width should be 30 feet unless for special uses such as school bus drops. The width shown applies to rural routes and most city streets including neighborhood business, residential, and industrial streets. For joint entrances center on property lines, the entrance width may increase 5 feet rounded to the nearest 5 foot interval but will not exceed 45 feet. In rural areas (open ditch roadways) widths for paved entrances should include an additional 4 feet for shoulders (Min. 2 feet shoulders each side).
2. The radius (R) for agricultural uses will vary according to the following intersecting acute angles:

Table 2: Agricultural acute angle and radius

Acute Angle	Acute Radius Decrease	Obtuse Radius Increase
85° - 90°	0	0
75° - 85°	5 ft	5 ft
65° - 75°	5 ft	10 ft
60° - 65°	10 ft	15 ft

Where the entrance radius specified is greater than the distance between the back of curb and the front edge of the sidewalk the radius may be reduced to meet the available space but should be no less than 10 feet. An option to the radius under this condition is the use of flared entrances. When a flare is used, it should be 3-feet wide and should be constructed from the back of curb to the sidewalk. If no sidewalk exists, flares should be 10 feet long.

3. For individual properties, the number of entrances will be as follows:
 - a. **Single Family (SF) Residential.** In general, each SF residential property shall be limited to one access point. However, where houses are located on corner lots, have extra wide frontage, or on heavy traveled roadway more than one access point may be permitted to eliminate backing out on the heavy traveled roadway.
 - b. **Multi-Family (MF) Residential.** In general, access shall be determined by information provided by the Owner/Developer in a Traffic Impact Report and by comments generated during the Jurisdiction Engineer's review and acceptance of that report.
 - c. **Commercial.** In general, commercial property having less than 150 feet of frontage and located mid-block shall be limited to one access point to the street. An exception to this rule may be where a building is constructed in the middle of a lot and parking is provided for each side of the building. A second access point may be allowed for commercial property having more than 150 feet of frontage. For commercial property located on a corner, one access to each street may be permitted provided lot dimensions are adequate from the intersecting street to the proposed entrance. (See Section 5I-3, Tables 2A and 2B)
 - d. **Industrial.** Access shall be determined on a case-by-case basis. The Jurisdiction will consider good traffic engineering practice and may require information to be provided by the applicant in a Traffic Impact Report. (See Section 5I-3, Tables 2A and 2B)
 - e. **Agricultural.** Access with adequate frontage may be authorized with more than two accesses at not less than 300 feet intervals provided a minimum distance of 30 feet from the inlet and outlet of two adjacent culverts.

In all cases, the minimum location of the access will be the taper width or radii width from the property line. In general, all construction must occur only on the property owners frontage.

4. Minimum acute angle (A) is measured from edge of pavement and is generally based on one-way operation. For two-way driveways, and in high pedestrian activity areas, the minimum angle should be 70 degrees. Entrances should be placed at 90 degrees whenever possible.
5. The entrance pavement thickness (T) is based on the following:

PCC – Class "A" or "C"- 4000 psi

HMA – Greater than or equal to 100K ESAL (optional for rural area).

For those entrances not paved, 6 inches (min.) of Class "A" gravel will be required.

D. Sight distance

1. Sight distance is based upon AASHTO stopping sight distance criteria. However, the height of an object is increased from 2 feet to 3.5 feet to acknowledge an approaching vehicle as the "object" of concern. Therefore, sight distance at an access location is measured from the driver's height of eye (3.5 feet) to the height of approaching vehicle (3.5 feet).
2. An access location should be established where desirable sight distance is available, as shown below.

Table 3: Desirable sight distances

Design Speed (mph)	Intersection Sight Distance - Left Turn from Stop (ft)	Intersection Sight Distance - Right Turn from Stop and Crossing Maneuver (ft)
55	610	530
50	555	480
45	500	430
40	445	385
35	390	335
30	335	290
25	280	240

Note: the sight distances shown above are for a stopped passenger car to turn onto or cross a two lane roadway with no median and grades of 3% or less. For conditions other than those stated, refer to the 2001 AASHTO "Green Book" for additional information.

This table is based on Exhibit 9-55 Exhibit 9-57 of the 2001 AASHTO "Green Book."

3. On a four-lane divided primary highway where access is proposed at a location not to be served by a median crossover, sight distance is required only in the direction of the flow of traffic.

E. Driveway grades

1. **Slopes vs. speed differential.** Along older urban arterial streets, it is common to find rather steep driveways. These were often constructed this way to allow the driveway and parking lots to drain more quickly and to save earthmoving costs. Most recently-constructed arterials feature flatter driveway slopes that better serve safe traffic flow.

The reason that driveway slope is important has to do with a concept called speed differential. Turning vehicles must slow appreciably to enter a driveway. The steeper the driveway, the more vehicles must slow in order to prevent "bottoming out". Speed differential is the difference between the speed of vehicles that are continuing through versus those that are turning into driveways. For instance, if the through traffic generally moves at 35 miles per hour and cars have to slow to 10 miles per hour to enter a driveway, the speed differential at that driveway is 25 miles per hour.

Table 4: Drive slope and entry speed

Driveway Slope	Typical Driveway Entry Speed
Greater than 15%	Less than 8 mph
14 to 15%	8 mph
12 to 13%	9 mph
10 to 11%	10 mph
8 to 9%	11 mph
6 to 7%	12 mph
4 to 5%	13 mph
2 to 3%	14 mph
0 to 2%	About 15 mph

Source: Oregon State University, 1998

A speed differential much above 20 miles per hour begins to present safety concerns. When the speed differential becomes very large (say, 30 to 35 miles per hour), the likelihood of traffic crashes involving fast-moving through vehicles colliding with turning vehicles increases very quickly. Rear-end collisions are very common on roads and streets when large speed differentials exist and the density of commercial driveways is high. When the speed differential is high, it is also more likely that when crashes do occur they will be more severe, causing greater property damage and a greater chance of injury or fatalities. Keeping the speed differential low is very important for safety reasons, as the table below indicates.

Table 5: Speed differential and crashes

When the Speed Differential Between Turning and Through Traffic Is:	The Likelihood of Crashes Is:
10 miles per hour	Low
20 mph	3 times greater than at 10 mph
30 mph	23 times greater than at 10 mph
35 mph	90 times greater than at 10 mph

Source: Oregon State University, 1998

2. **Vertical profile.** A driveway's vertical profile should allow a smooth transition to and from the roadway. The National Highway Institute's course workbook on Access Management recommends the following maximum driveway slope angles for urban/suburban streets:

- Arterial 3 to 4%
- Collector 5 to 6%
- Local Less than 8% (may use 9% in special areas)

These slopes were all chosen to keep the speed differential at or below 20 miles per hour. See Figures 2A and 2B.

Figure 2A: Typical section - commercial entrance

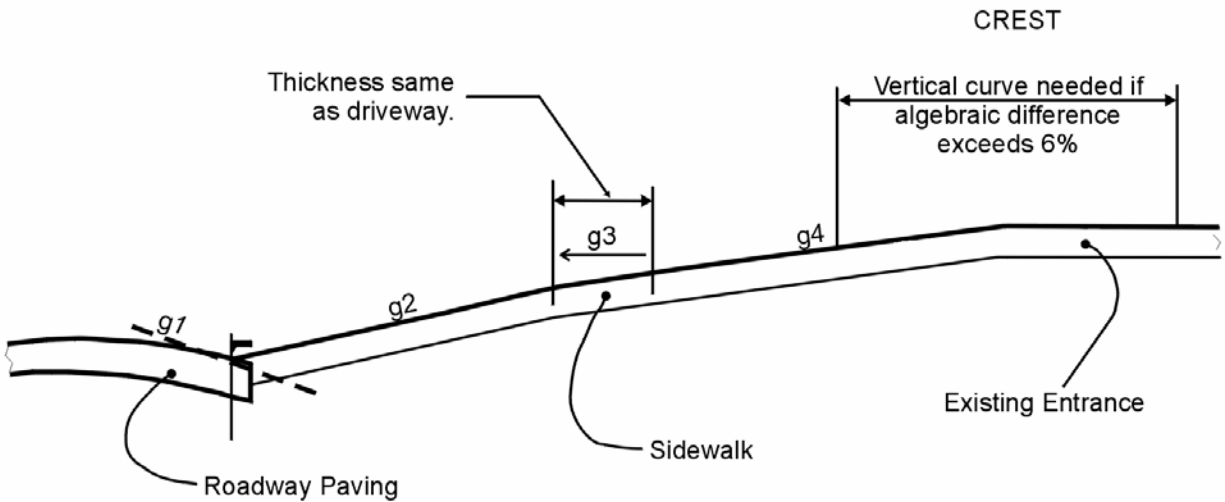

SECTION - TYPICAL COMMERCIAL/INDUSTRIAL ENTRANCE

1. g1 and g2 - Algebraic difference between g1 and g2 shall not exceed 9% (See Section 5I-4, E, 2).
2. g3 - Maximum slope 2%.
3. g4 - Maximum slope 9%; if additional slope is needed beyond 9%, a vertical curve may be used so as to exceed the algebraic difference of 6%.
4. If the above grade restrictions require a depressed sidewalk through the driveway, a transition section shall be provided between the normal sidewalk grade and the depressed section (See Figure 3). The transition section shall vary both longitudinally and transversely within the grades allowed. As a general rule, use the following transition lengths:

Elevation Difference from normal sidewalk grade	Transition distance
1 to 2 in	8 ft
2 to 4 in	12 ft
4 to 6 in	16 ft
Greater than 6 in	Desirable max. slope is 16:1 Absolute max. slope is 12:1

Figure 2B: Typical section - residential entrance

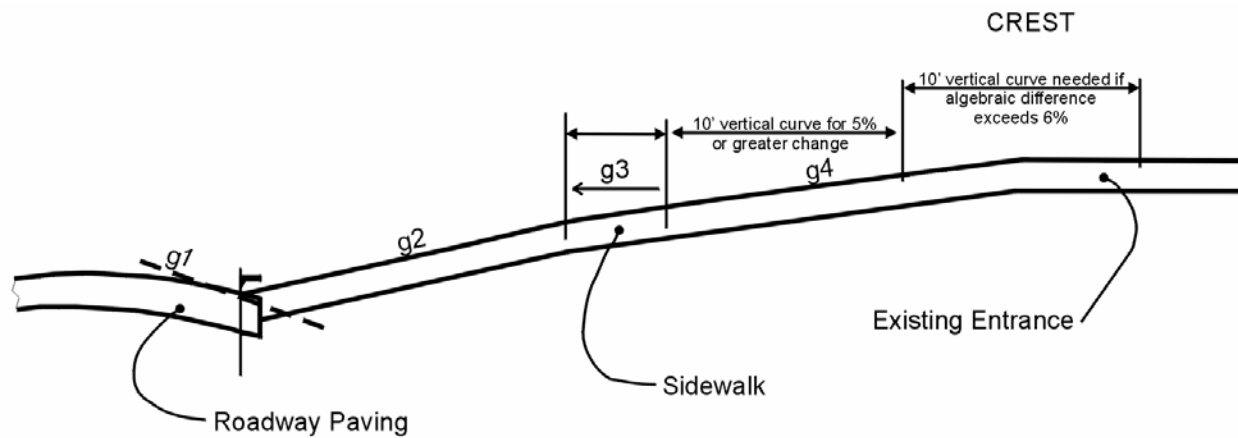

SECTION - TYPICAL RESIDENTIAL ENTRANCE

1. g1 and g2 - Algebraic difference between g1 and g2 shall not exceed 12% (See Section 5I-4, E, 2).
2. g2 and g3 - Algebraic difference not to exceed 8%.
3. g3 - Maximum slope 2%.
4. g3 and g4 - Algebraic difference not to exceed 12%.
5. g4 - Maximum Slope 14% - Use vertical curve between g3 and g4 if grade change is 5% or greater.
6. If the above grade restrictions require a depressed sidewalk through the driveway, a transition section shall be provided between the normal sidewalk grade and the depressed section. As a general rule, use the following transition lengths:

Elevation Difference from normal sidewalk grade	Transition distance
1 to 2 in	8 ft
2 to 4 in	12 ft
4 to 6 in	16 ft
Greater than 6 in	Desirable max. slope is 16:1 Absolute max. slope is 12:1

Figure 3: Typical commercial entrance with handicap ramp

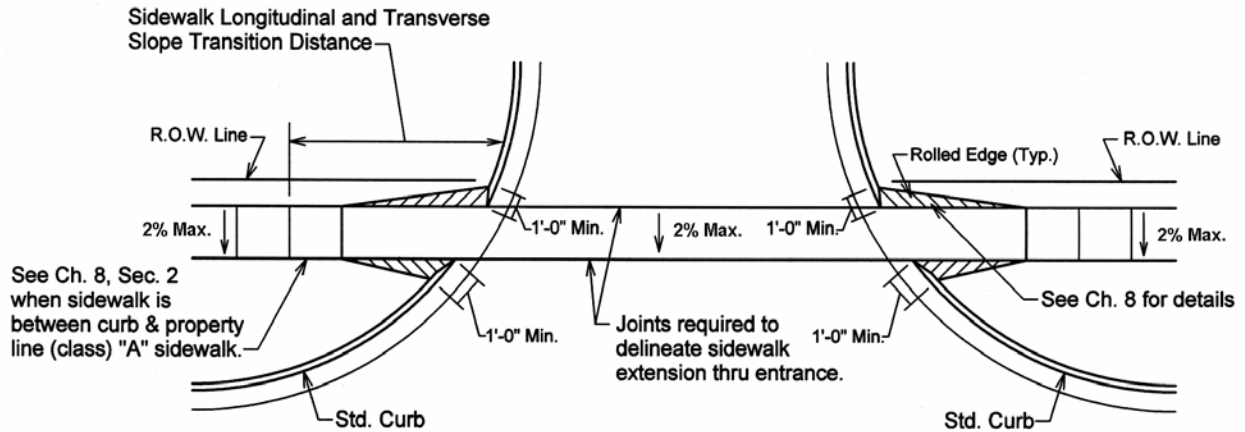

PLAN VIEW - TYPICAL COMMERCIAL ENTRANCE WITH HANDICAP RAMP

SIDEWALK LONGITUDINAL AND TRANSVERSE SLOPE TRANSITION DISTANCE

If the above grade restrictions required a depressed sidewalk through the driveway, a transition section shall be provided between the normal sidewalk grade and the depressed section. The transition section shall vary both longitudinally and transversely. As a general rule, use the following transition lengths:

Elevation Difference from normal sidewalk grade	Transition distance
1 to 2 in	8 ft
2 to 4 in	12 ft
4 to 6 in	16 ft
Greater than 6 in	Desirable max. slope is 16:1 Absolute max. slope is 12:1

3. Non-curb and gutter roadways

- a. Private drive access to local, collector, or arterial streets that have no curb and/or gutter improvements should be constructed to meet the following requirements. Figure 5 shows the required grades and dimensions. Heavy used driveways connected to existing gravel roadways may require an 8-inch-deep compacted Class "A" crushed stone base material. The pavement shall be extended to the proposed pavement width, if known, or 15.5 feet from the centerline, if not known. A culvert properly sized for the ditch flow should be installed at the established roadside ditch flowline beneath the private drive access. Minimum size for the culvert shall be 15 inches and 18 inches desirable. The culvert shall be either corrugated metal or reinforced concrete pipe with minimum of 1 foot of cover over the pipe.
- b. For Farm to Markets (FM) roads when grading on new construction or complete reconstruction projects on paved (or to be paved) FM roads, the following will apply:
 - 1) When culvert is not required, the following slopes will apply (see Figure 4 for area location):
 - 10:1 slope or flatter from shoulder line to ditch bottom in clear zone area.
 - 6:1 slope or flatter from clear zone area to the right-of-way line.
 - 10:1 to 6:1 transition zone.
 - 2) When culvert is required, the following slopes will apply (See Figure 5 for area locations)
 - 8:1 slope or flatter from shoulder line to normal placement of a culvert.
 - 6:1 slope or flatter from culvert area to the right-of-way line.
 - 8:1 to 6:1 transition zone.

For remaining open ditch roadways (paved or non-paved), the sideslopes will be 6:1 for posted speeds of 40 mph or greater and 4:1 for posted speeds of less than 40 mph.

Figure 4: Entrance off a paved (or to be paved) rural roadway
no drainage pipe required

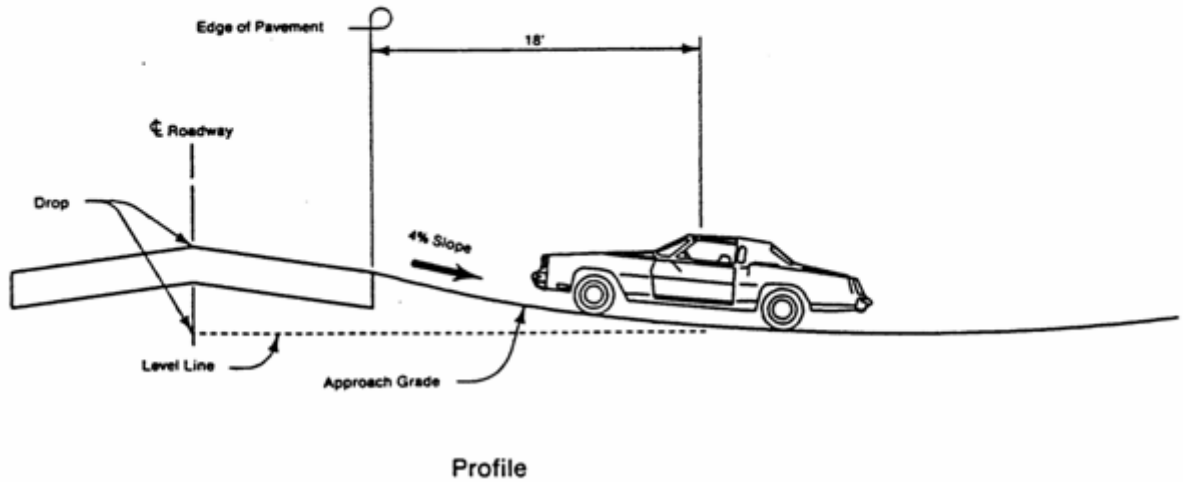
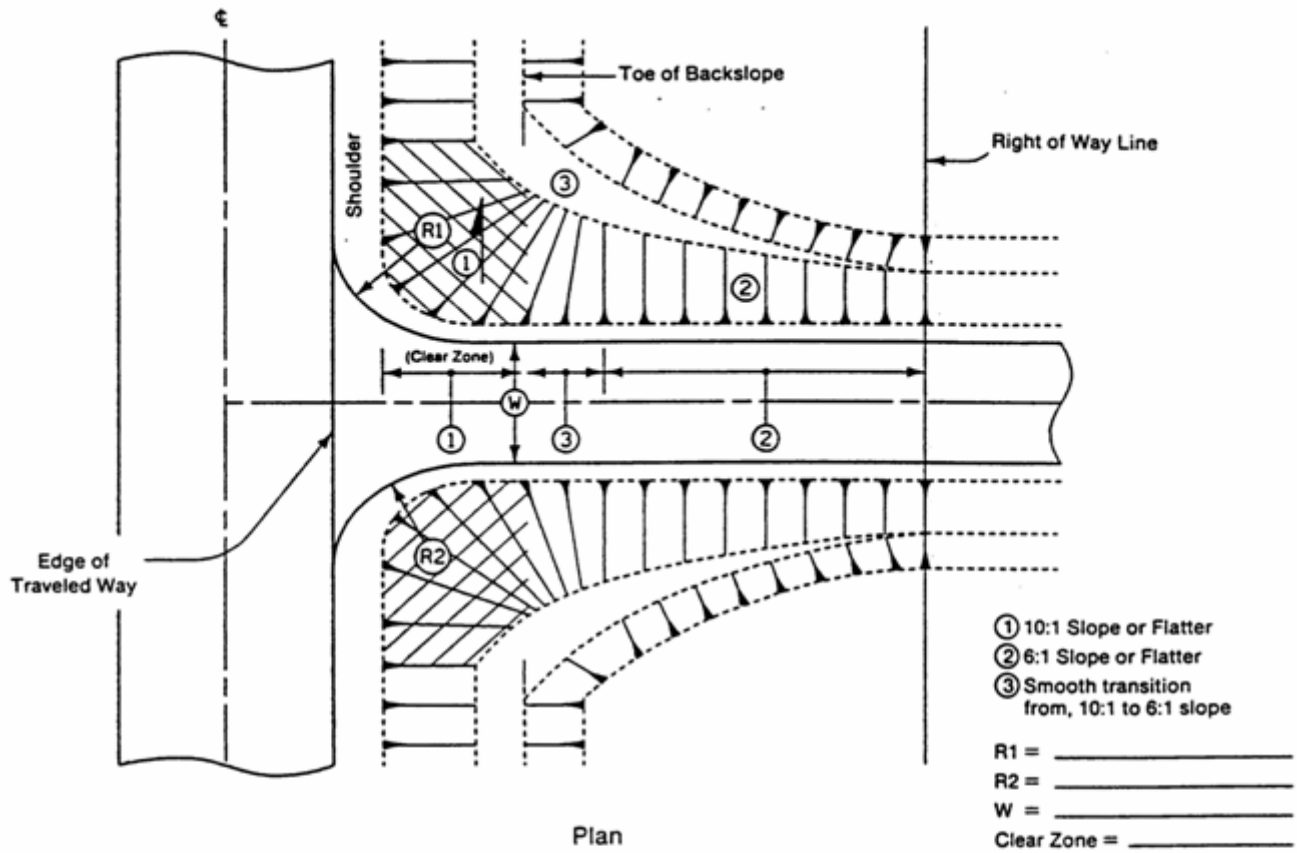
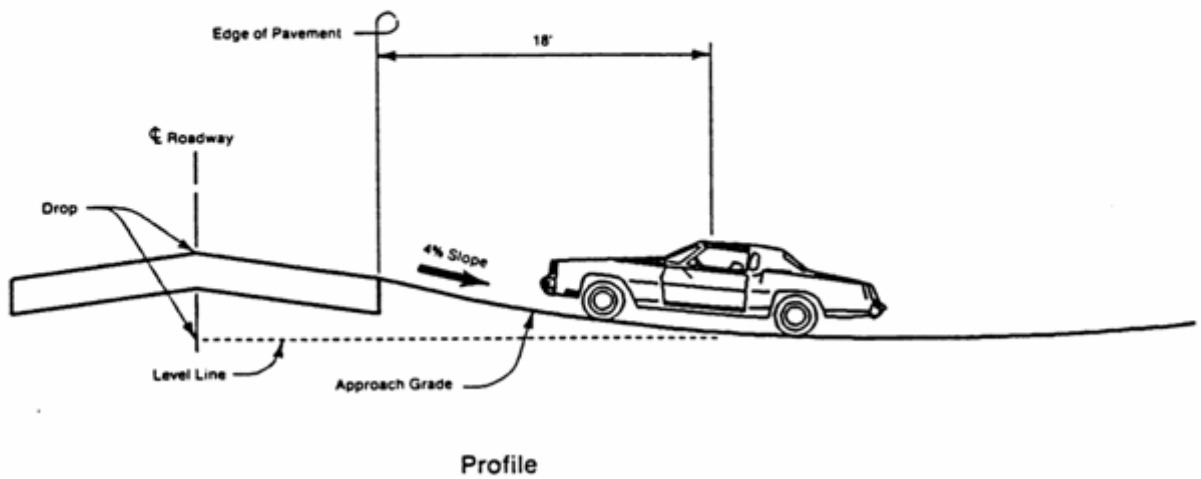
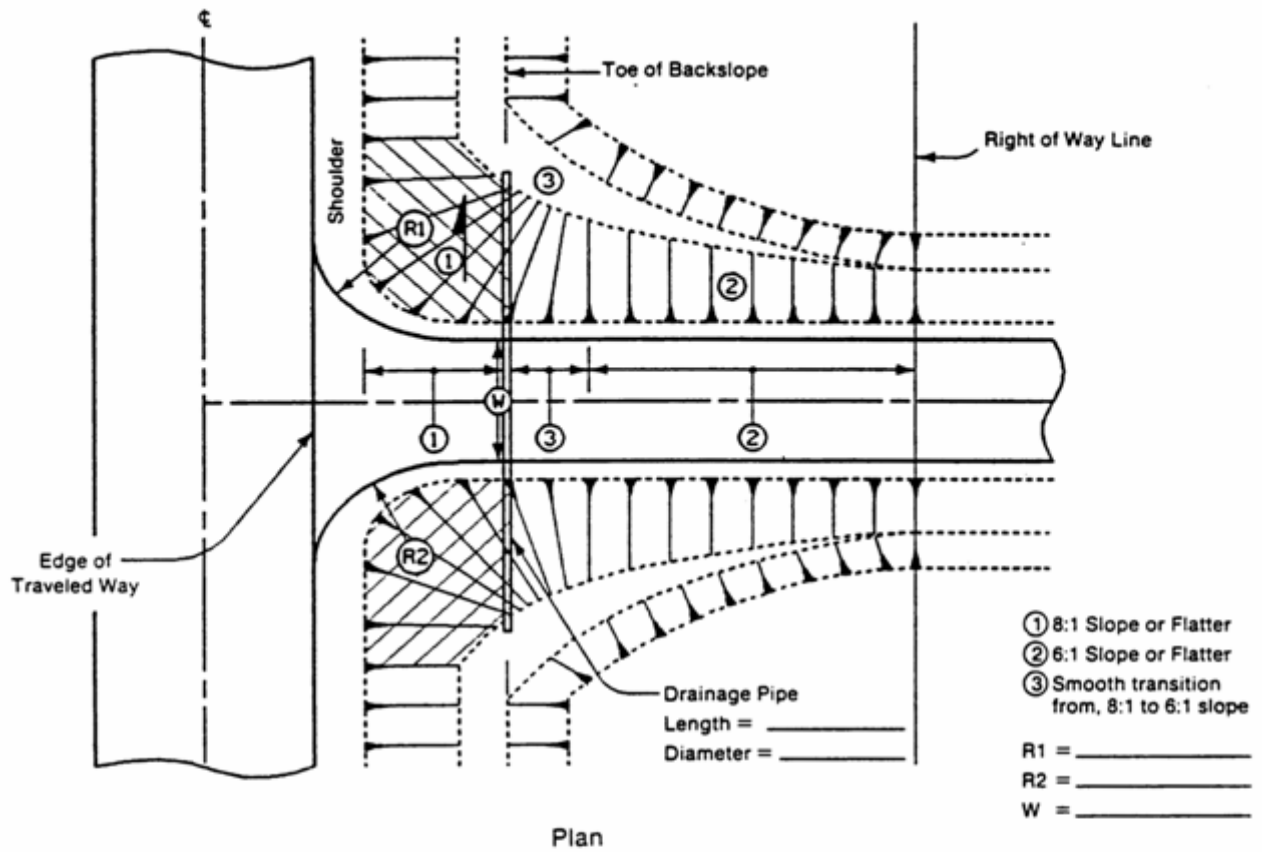

Figure 5: Entrance off a paved (or to be paved) rural roadway



F. Other criteria

1. **Utility conflicts.** Any adjustments made to utility poles, street light standards, fire hydrants, catch basins or intakes, traffic signs and signals, or other public improvements or installations, which are necessary as the result of the curb openings or driveways, should be accomplished without any cost to the Jurisdiction.
2. **Access signs.** Driveway approaches, whereby the driveway is to serve as an entrance only or as an exit only, shall be appropriately signed by, and at the expense of, the property owner subject to approval of the Jurisdiction Engineer.
3. **Abandoned driveways.** Any curb opening or driveway which has been abandoned shall be restored by the property owner.
4. **Offset radius and driveway tapers.** By providing offset radius with driveway tapers the turning vehicle speed change from the following vehicle is reduced and helps move the turning vehicle away from the following vehicle which reduces rear-end crashes. Because of right-of-way restrictions, this method cannot always be used. The following is a typical taper system that is effective in allowing vehicles to access entrances to reduce rear-end crashes.

Figure 6: Offset radius and driveway tapers

